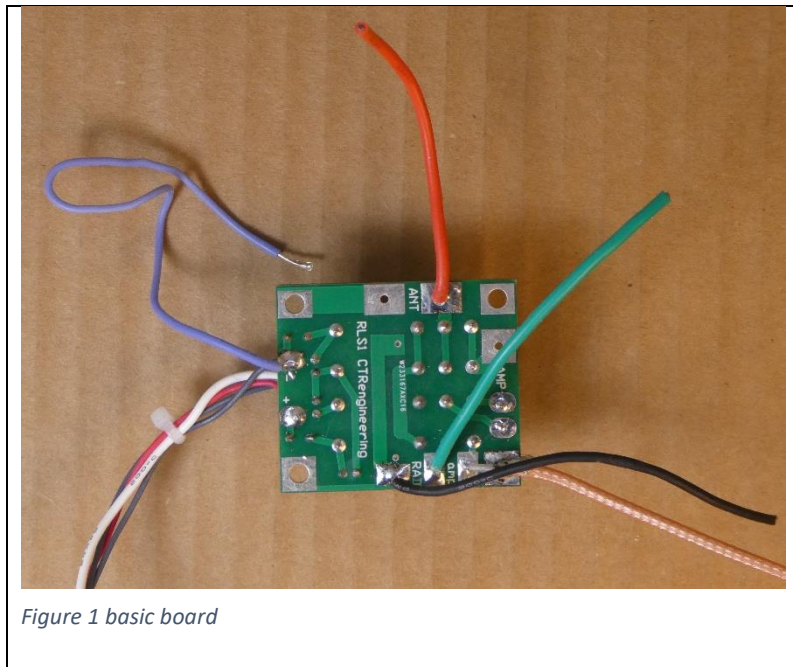


# UnRS-811 Installation Instructions

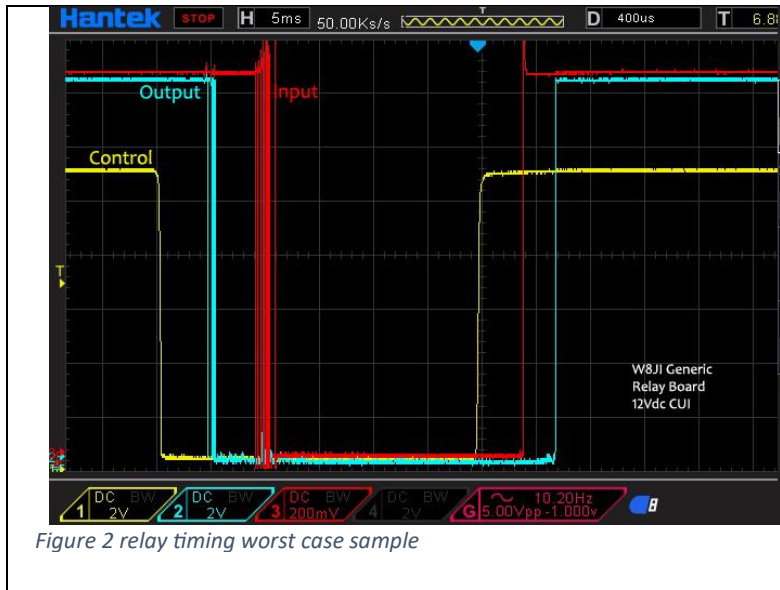
March 7, 2026 Rev 0

The UnRS-811 is a simple relay upgrade or replacement for all MFJ/Ameritron AL-811 style amplifiers. This kit consists of a true time-sequenced 12Vdc relay system, custom wire harness, two Zener diodes, assorted heatshrink, and 3M installation tape.



This unit is **properly time sequenced**. Sequencing prevents amplifier tank and relay system damage. **The maximum radio delay required will be 10mS or less**. Most radios, like the IC7300, have this delay (or longer) without adding additional menu setting delays.

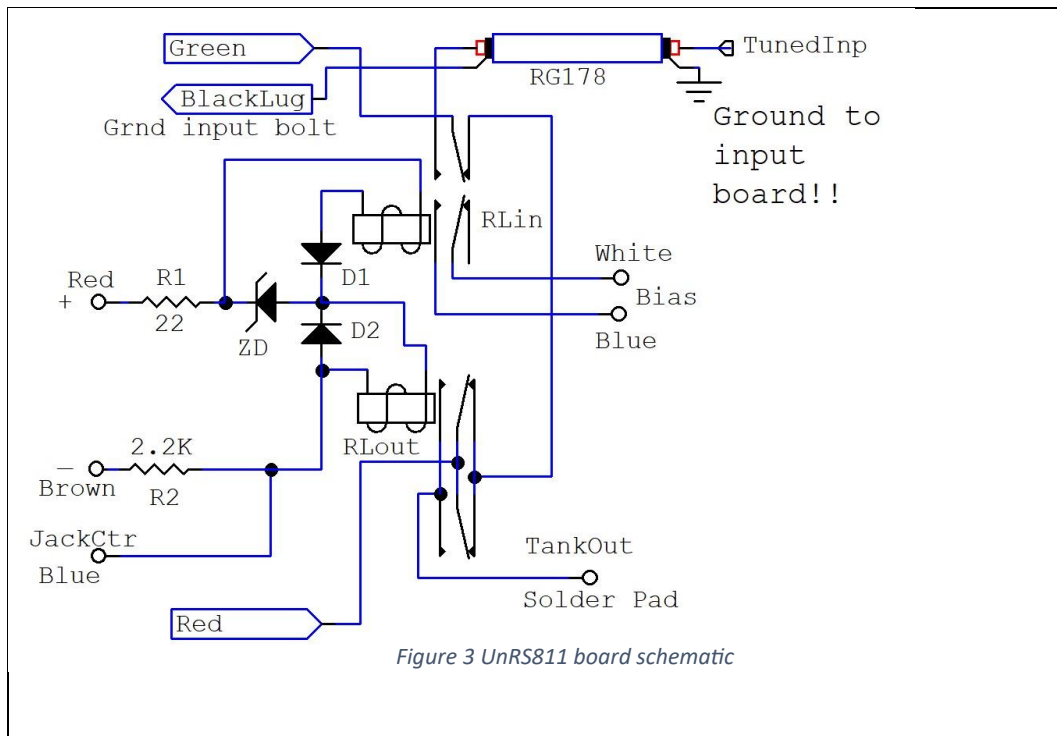
**Note:** One popular Internet source gives false timing information for amplifiers. Follow these instructions. A good solid-state buffer will generally neither benefit nor will it hurt the system. **Never use a relay-style keying buffer**. Buffers or isolators using relays always add at least 5mS of additional unnecessary send-line latency.



The relay jack keying voltage will be +12-volts open circuit with a closed current less than 100 mA. Virtually any radio will handle this control level without additional relay line buffers. Relay line buffers do not add radio arc protection.

***This kit relocates bias switching.*** To ease installation, bias and bias switching on the factory rear panel tuned input circuit board is not used. This system must either use our KF811 or KF811H fan kits bias diode system or use the one or two 1N5335B 3.9V 5W Zener diodes supplied with this kit for bias. Either system works the same. Zener-type bias diodes must wire with the cathode or banded end toward the transformer filament center tap. The unbanded end of the Zener(s) faces the blue meter shunt wire direction, away from the transformer filament-cathode center tap.

You will need standard hand tools and a small good clean pencil-type soldering iron of at least 30-watts. This kit requires good hobby-level soldering skills. You must know how to tack, sweat, or standard solder and flow the solder properly and neatly. Practice on scrap first.



## Instruction Steps

- 1.) Unplug amplifier, be sure HV is at zero, and place the amplifier flat on a clean well-lit repair bench or desk
- 2.) Remove amplifier cover
- 3.) Inspect the tuned input board on the rear panel. If MFJ/Ameritron grounded the output coax to the circuit board, you will need to move that cable shield to a chassis ground! Grounding the tank coax shield to the input circuit board ground or backplane is a factory modification error. Keep this in mind!

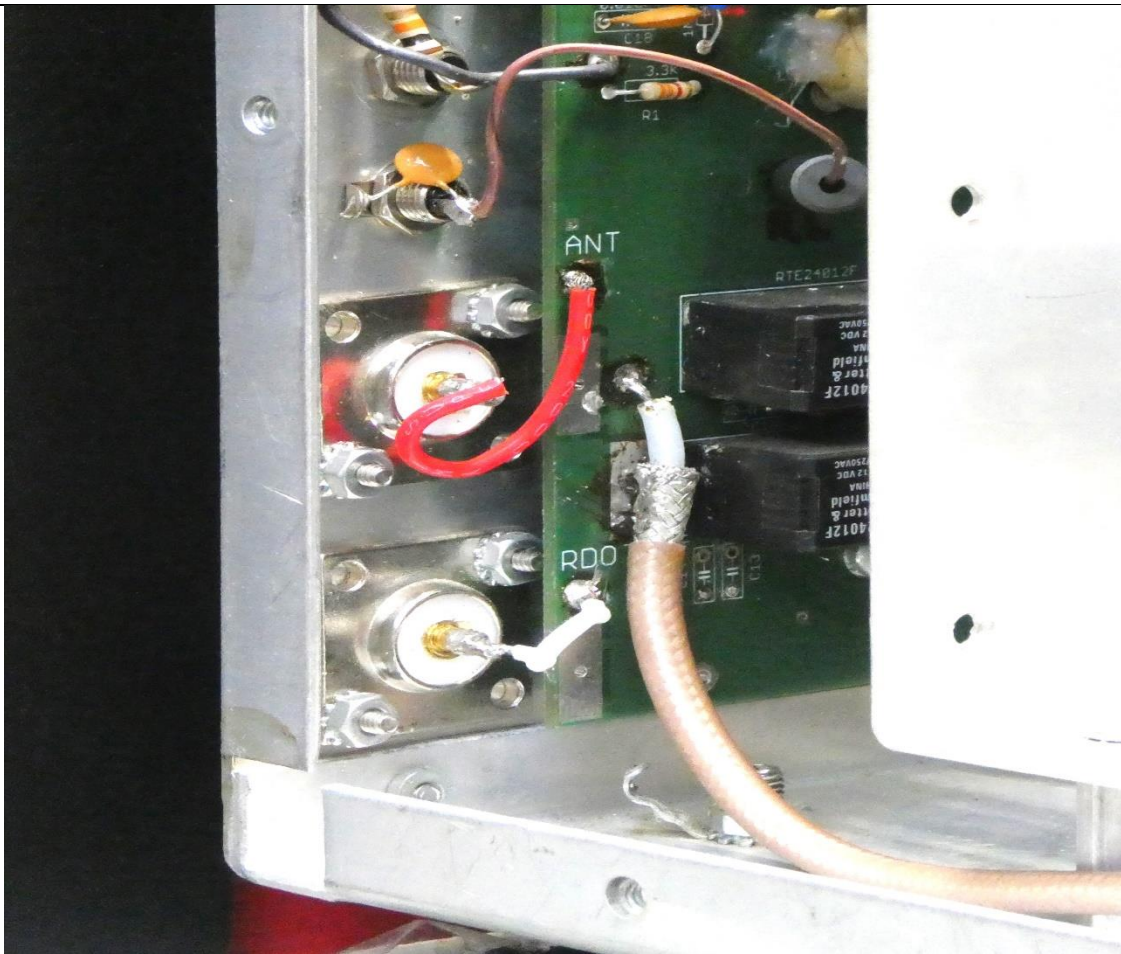


Figure 4 never ground shield to PC board!

- 4.) Regardless of OEM relay or amplifier generation, remove all wires from the PC board relay system that connect to the RELAY jack center pin and to the two RF connector center pins. These three board connections are no longer. Also, unsolder (do not cut) the rear end of the coax or single wire, whichever was used. Do not remove or damage the small bypass capacitor from the relay jack center pin.

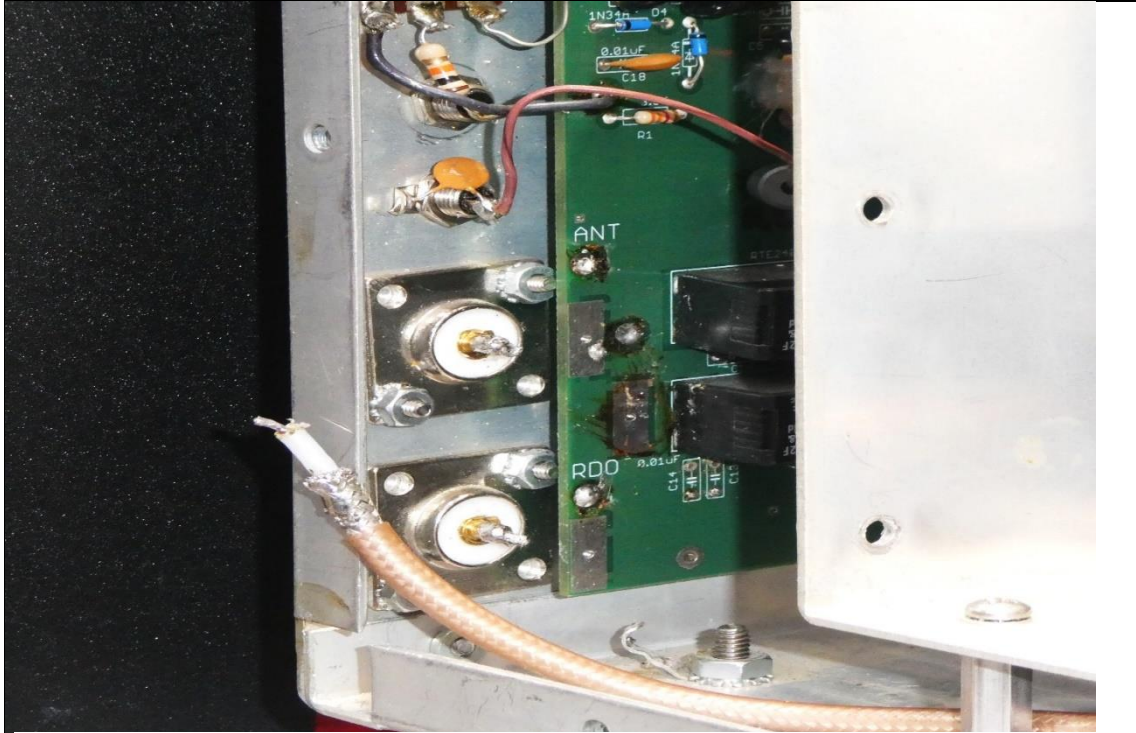


Figure 5 unsolder and discard relay wires. This includes the brown/black, bare, or blue wire to the Relay jack

**PC board was the wrong place to ground shield, chassis lug is correct place**

- 5.) Note the connector labels on your unit. Depending on year, the input connector and output connector can reverse position. Observe and match the connector heavy red output and heavy green input wires
- 6.) The new relay system comes with a small coax and three flying wires, plus a four-wire harness, already attached. The wire codes are:

Color	Function	Connection
Red	High power RF output to antenna	RF Out connector center pin (keep short)
Green	Low power RF input from radio	RF In connector center pin (keep short)
Black	Chassis ground for RF input	Ground lug on input connector (keep short)
Blue	Relay control line	Relay jack center pin (cut off the old wire)
White	<b>Harness</b> bias	Transformer center-tap via bias diodes
Blue	<b>Harness</b> metering	To blue at center of meter shunts
Red	<b>Harness</b> 12V switched stand by	Also common with TX LED positive
Brown	<b>Harness</b> for LED return	TX LED ground side

7.) Lay the relay board down on the relays and push the harness wire through along the back panel. It might help to temporarily tape the white wire end to the three twisted wires. The intentionally stiff twisted wires and temporary heatshrink "nose" make pushing easy. Use any path that lets the wires lay on the chassis and pass the existing amplifier wiring.



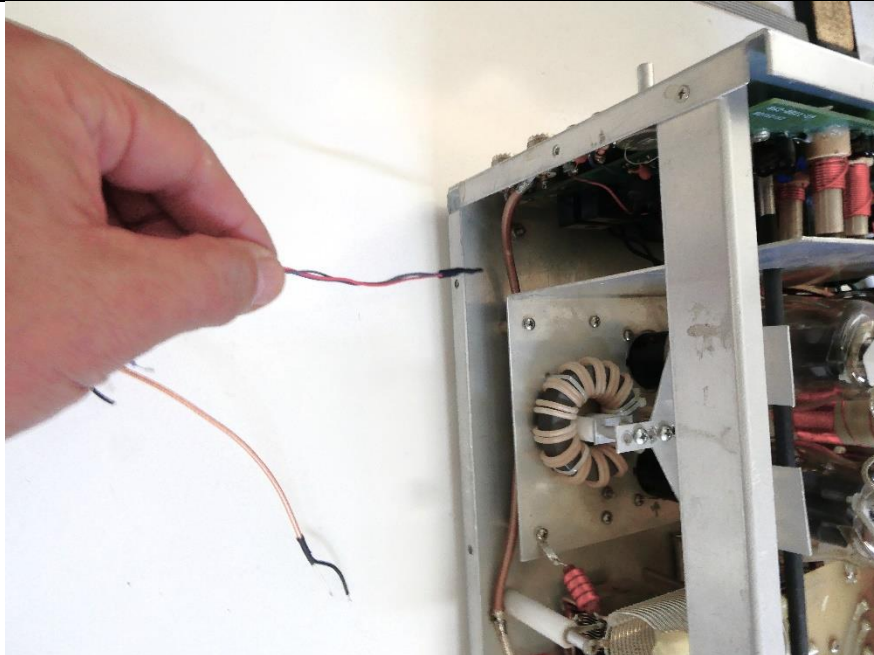


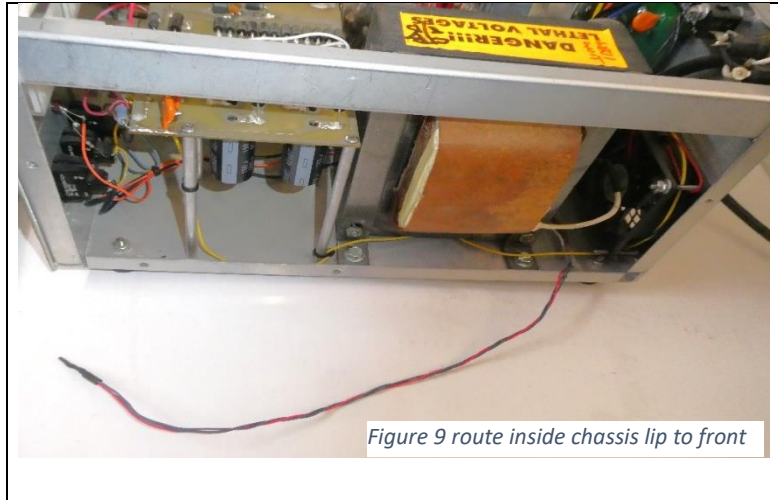
Figure 7 push harness in along back area

8.) Once pushed through, pull from the other side while moving the relay into final position

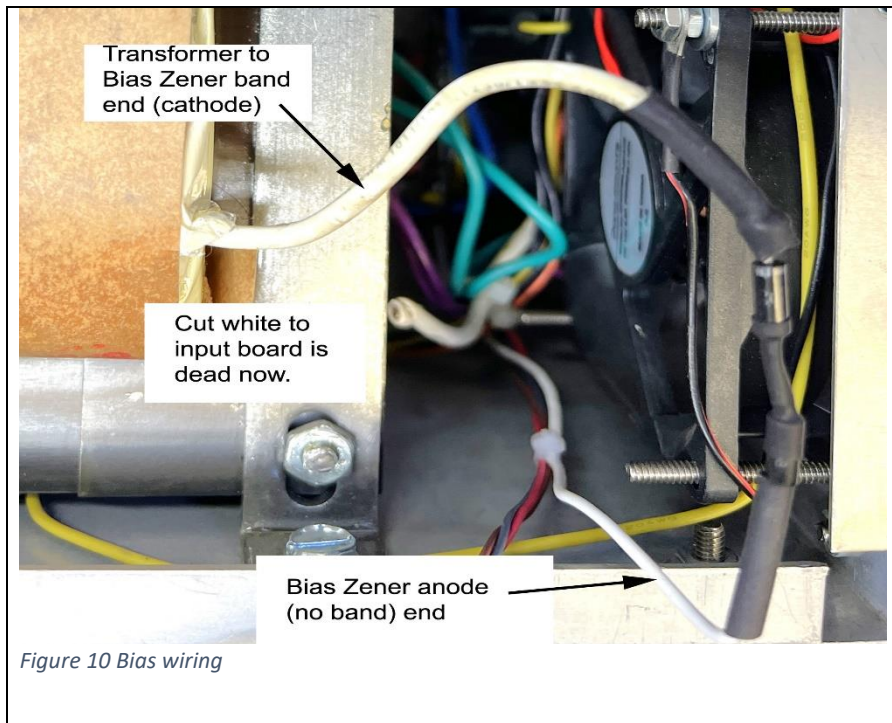


Figure 8 pull wire once through

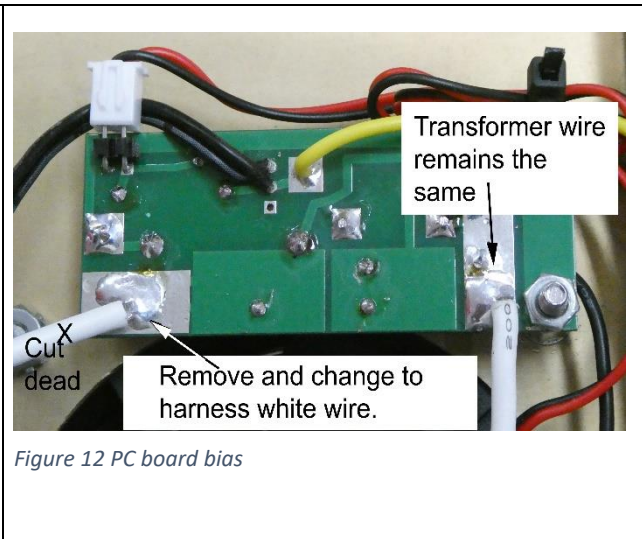
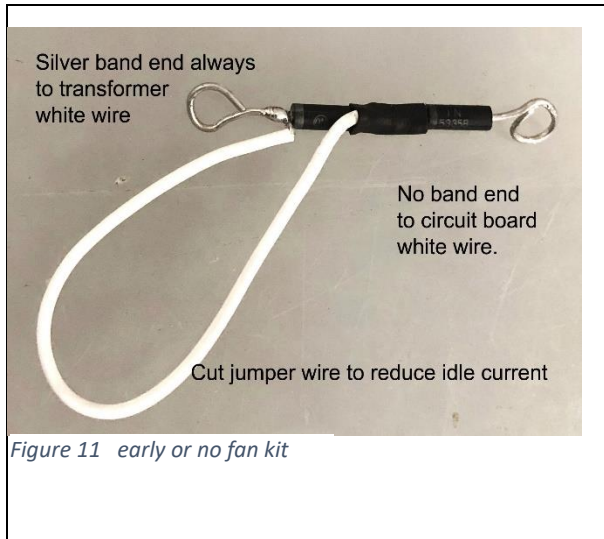
9.) Route wire along inside bottom edge toward front. These three wires will eventually connect by the front panel, blue to PC board metering and bias return. Red and Brown to TX LED and operate switch.



10.) The white harness wire connects to the white transformer wire through bias diodes. **Zener bias diodes have the silver band (cathode) toward the transformer.** **The unbanded Zener diode end goes toward the white harness wire.** The white harness wire connects with the blue harness wire in a relay contact to switch the tubes into conduction when the amplifier is placed into transmit mode.



Zener system in our fan kits:



- 11.) Harness Brown (LED), Red (12V SW Power), and Blue (metering resistor) harness wires connect as follows. First assess or understand the LED system that your amplifier has. Amplifiers with cube relays have a series resistor low-current LED system. No LED wiring changes are required. Amplifiers with the large open frame relay require cutting or crushing the existing 22- or 33-ohm resistor across the LED. Get rid of the LED resistor in open frame relay amps.
- 12.) Pre-tin the RED, BROWN, and BLUE harness wires with a good dot of fresh solder. You will find that proper flowed tack soldering of these wires is perfectly adequate. Route the harness inside the lip and against or inside the metal spacers so the harness is safe and neat. It can run with the fan 12V wire if present.

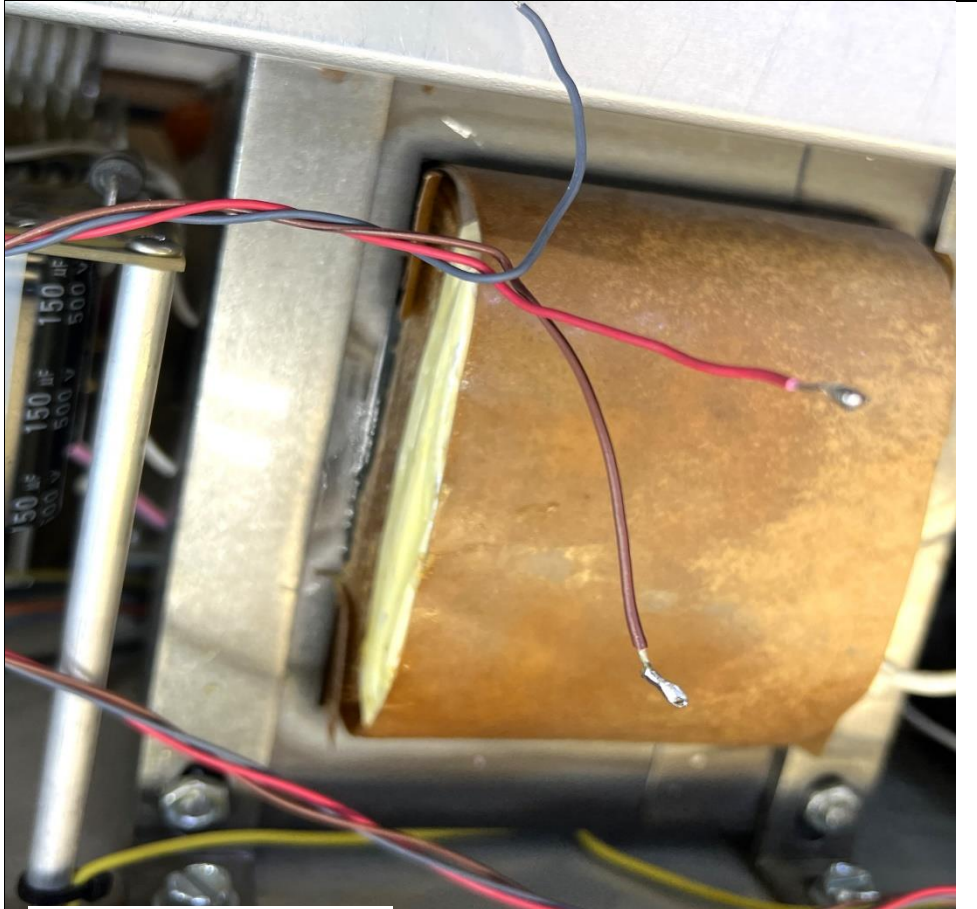
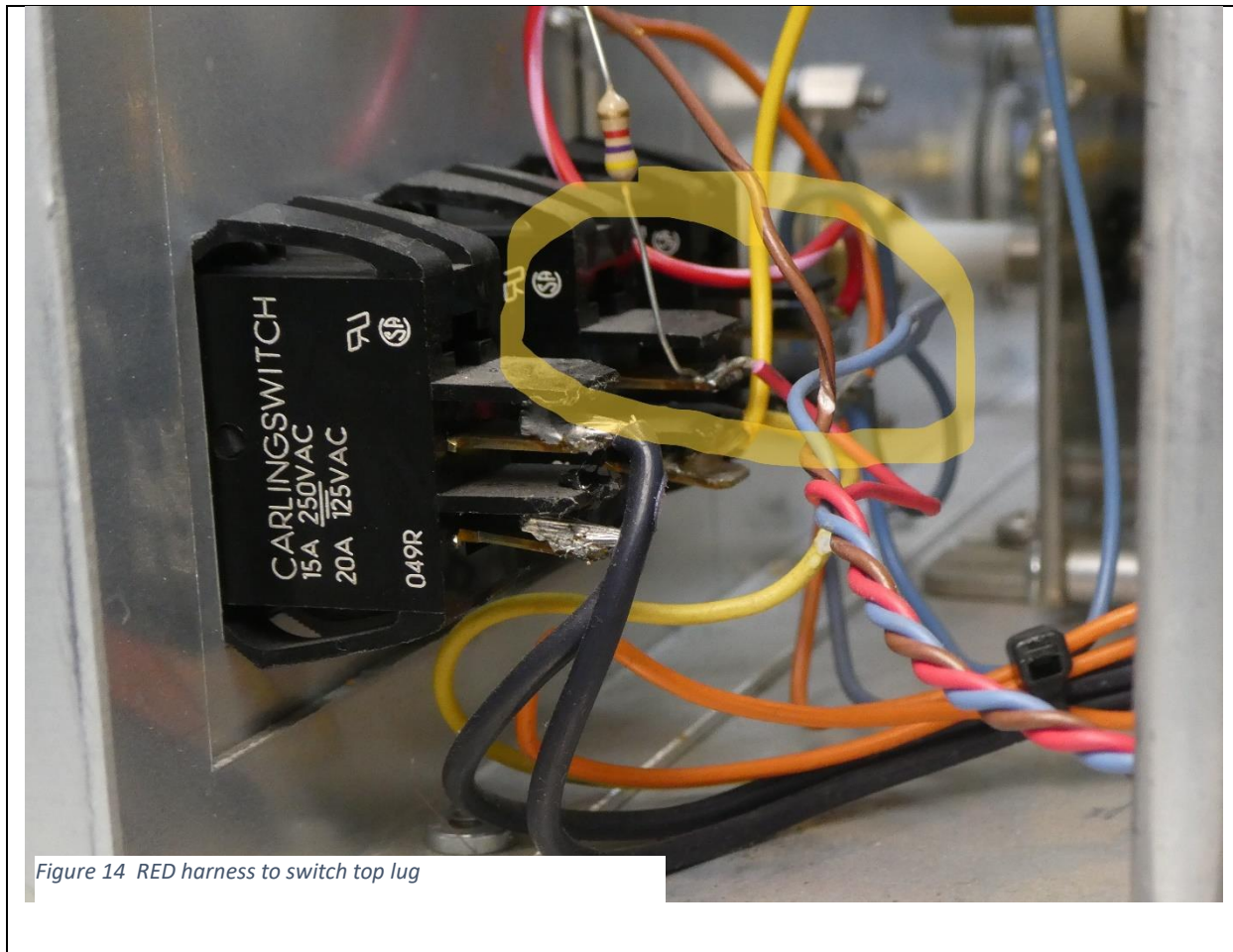


Figure 13 Pre tin and route wires

- 13.) The best way to wire is to connect the lowest and most inside difficult wire first, in the case the RED to the standby switch. The RED adds to the switch. Do not remove any wires from the switch. If you have an older open frame relay amplifier leave the red/white to the LED intact



- 14.) The BROWN harness wire should be connected next. It connects to the LED cathode; the sole function of this wire is to illuminate the Operate or TX LED. Remove the orange OEM factory wire from the LED cathode. The orange wire ran the old relay and now just becomes another dead unused wire. You can just tuck it out of the way or snip it off. Make sure all wires stay out of the plate tuning capacitor and away from high voltage filter capacitors

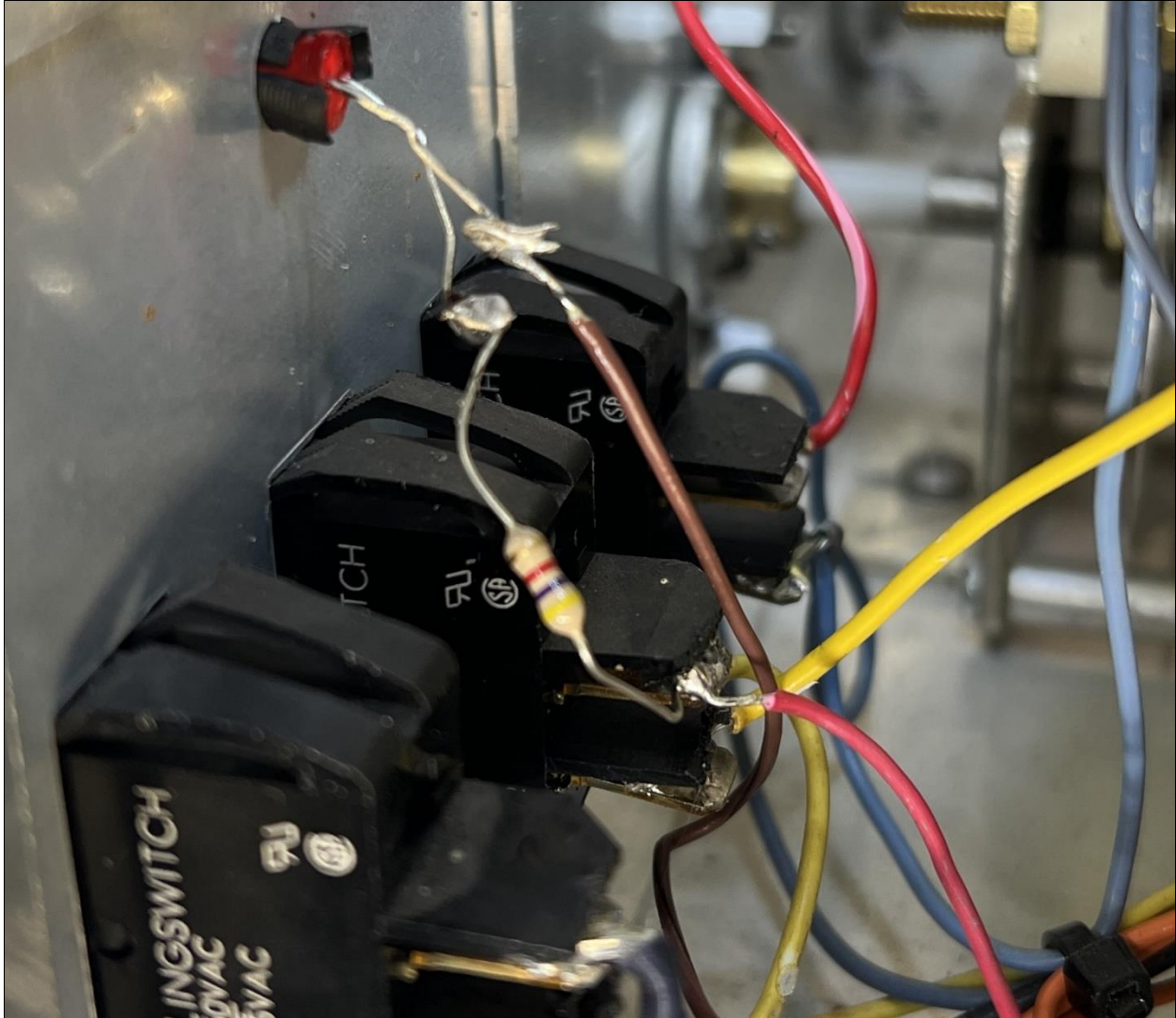


Figure 15 BROWN wire

- 15.)** The final harness wire connected is BLUE. It is the cathode and bias return from the relay normally open bias contact. It connects between the .6 ohm and 1.5-ohm meter shunts. All the other wires there are also blue. If you follow the blue one goes to the input board. You can leave that blue, cut it off, or unsolder it. It does not matter. Just do not let a wire get into the filter caps or into the plate tune capacitor. ***Be careful with these blue wires. If the meter shunt blue wires accidentally short to the adjacent ground traces the meters will not work correctly! This point should read nominally 1.5 ohms or so to chassis.***

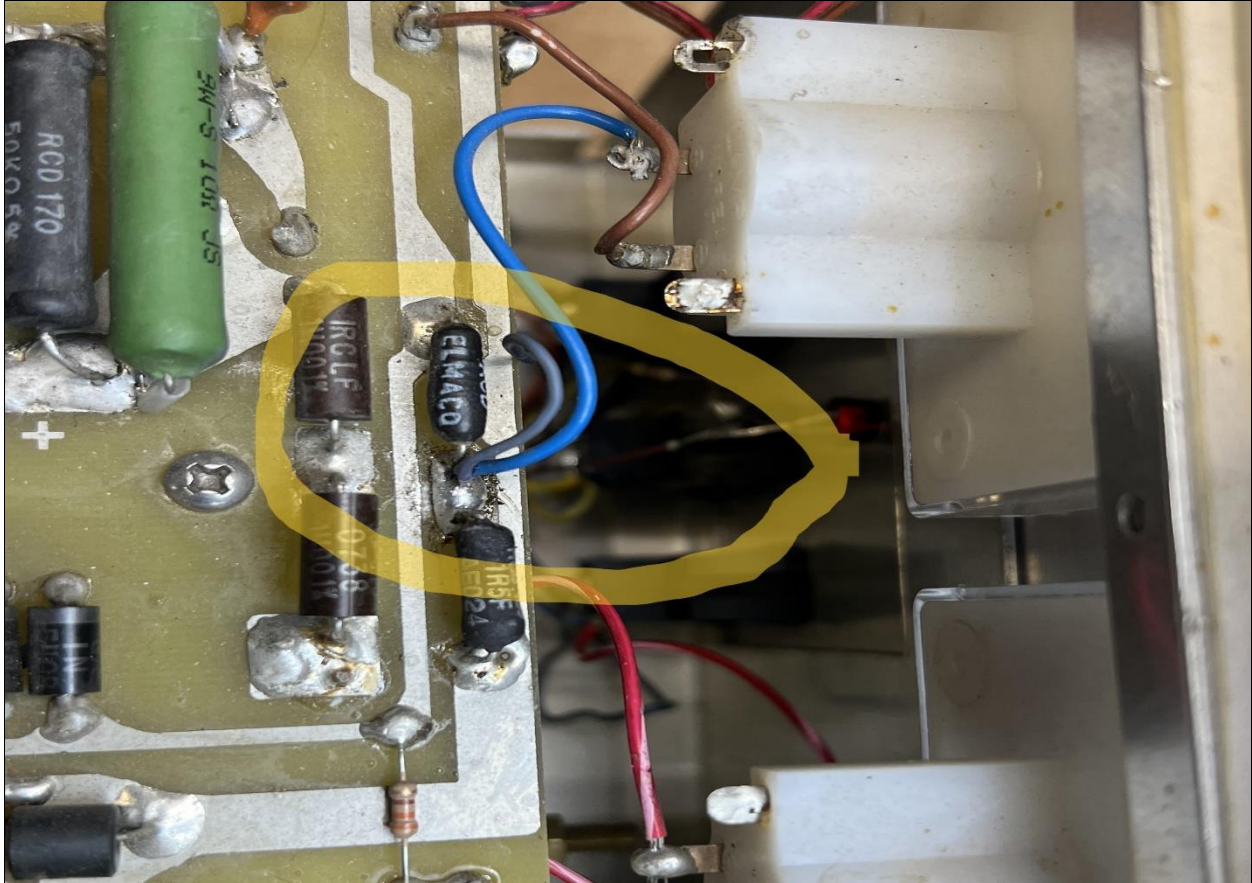
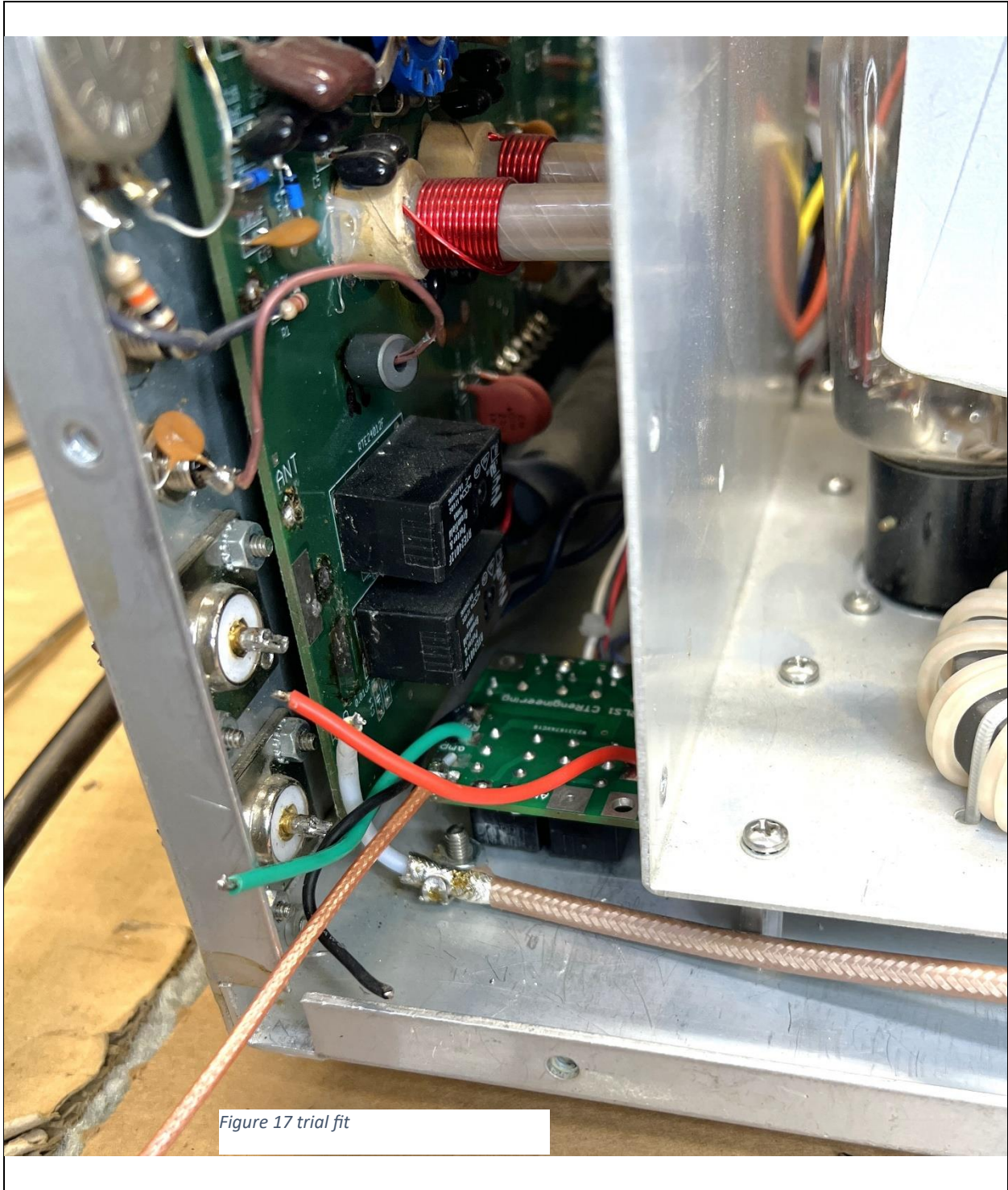


Figure 16 BLUE wire

- 16.) After double checking your work, the last area will be the RF connections. We did everything we could to make this easy and foolproof. Remember grounds and short lead lengths are important, mostly these things affect 15- and 10-meters. Again, follow the general rule of wiring from lowest and most obstructed most inward leads first, while doing upper and outward easy-access leads last. If you do not know how to prepare and alter coax neatly, I do have a video up on YouTube.
- 17.) Temporarily position the board with relays down just past the foot screw. This is to trial fit all wires before attaching the board with tape. Assure the RED RF output and GREEN RF input wires reach their respective center pins. Remember the two connectors reversed position in some years. The flying black wire on the board will always go to a (new) lug under an INPUT connector mounting nut. The small pre-

installed coax also has a black ground lead. That ground must connect to the Input circuit board ground plane. The ALC pot ground on the board is a good solder point



- 18.) Make sure the large coax cable's shield is properly grounded to the chassis. Any direct and short chassis connection is good. Under the foot mounting nut is good
- 19.) Clean and dry the chassis where the relay mounts. Mount the new board by attaching the bare tape to the two relay cases. Position and press the board to the chassis
- 20.) Next, solder the large coax center to the relay output AMP tank pad. Please be sure you get the correct pad. Look at the pictures. The AMP tank is next to the bias wires and the furthest most inward open pad. Because it is lowest and furthest in soldering, it is best to solder it first. Try to form the coax center wire as to not strain the wire and lift the board

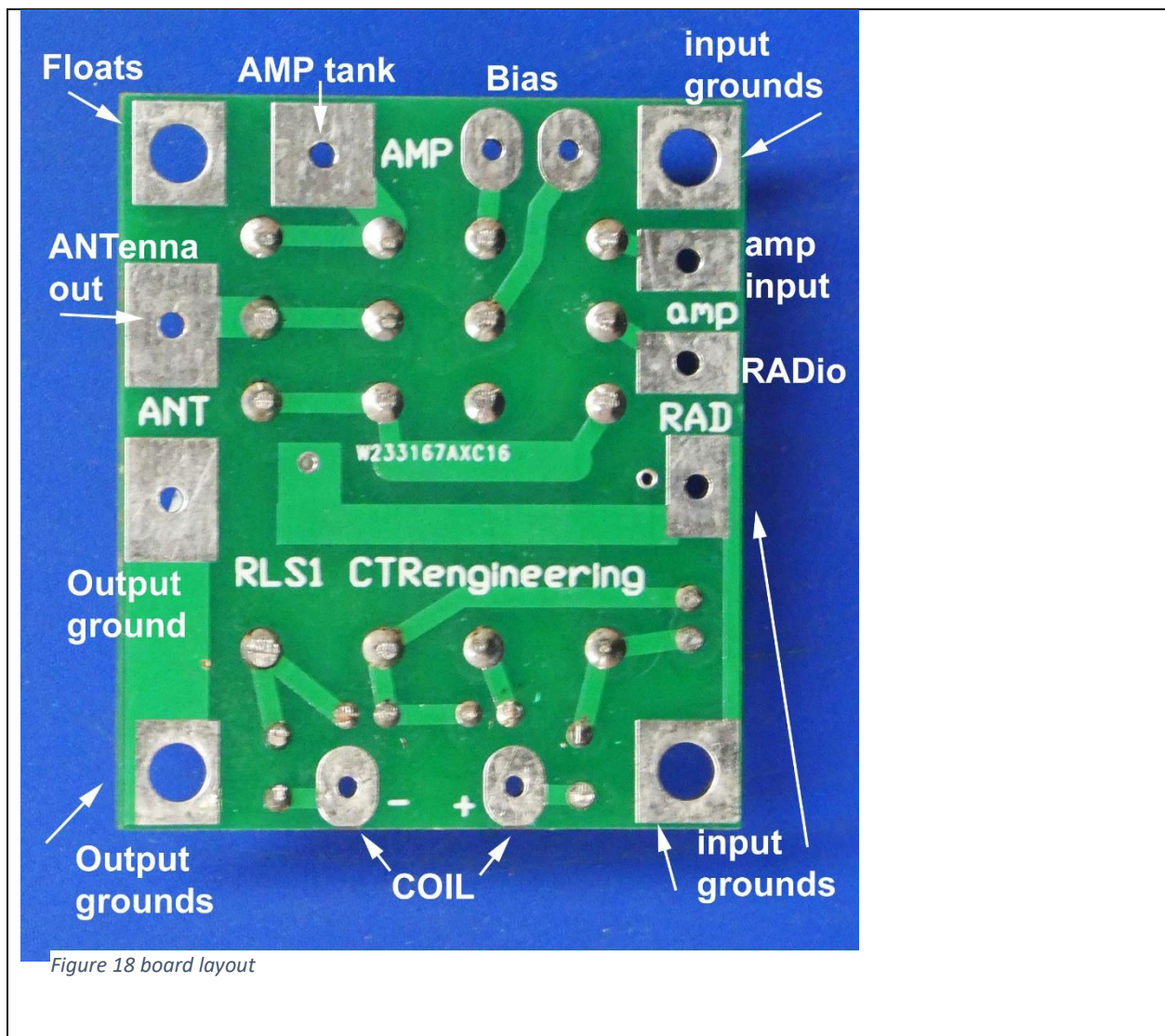


Figure 18 board layout

21.) After the large coax center (or single white lead from the tank output) is soldered to the pad shown as “AMP” tank, make sure the board can still rest without strain or being pulled. The center conductor of this coaxial lead from the tank can be extended with #18 or #20 wire if necessary

**Note:** Extending the center has no effect on operation. The shield ground point has a large effect. The shield must be direct to the chassis



Figure 19 Mount Board solder AMP out coax

- 22.) Now attach the lower SO-239 coaxial jack center pin wire. If it is the RF IN jack, it gets the large GREEN wire. It will also have the BLACK wire and ground lug under the nut. If (in some units) it is the RF OUT jack, it only has the large RED.
- 23.) Now attach the upper coaxial jack center wire. If it is the RF IN jack, it gets the large GREEN. It will also have the BLACK wire and ground lug under the nut. If (in most units) it is the RF OUT jack, it only has the large RED.

Note: The RED and GREEN wire lengths and positioning can affect pass-through and input SWR. Do not extend these leads needlessly.

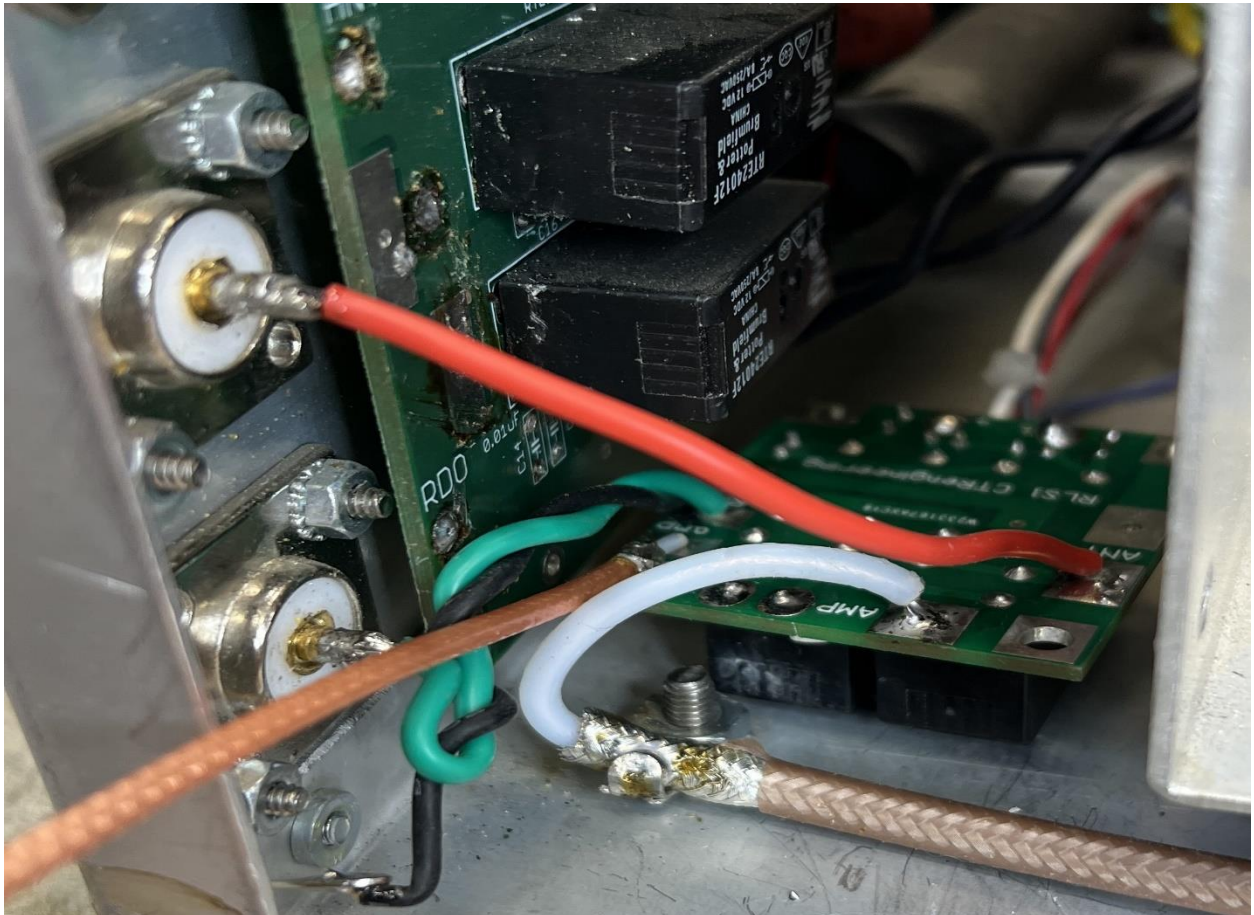
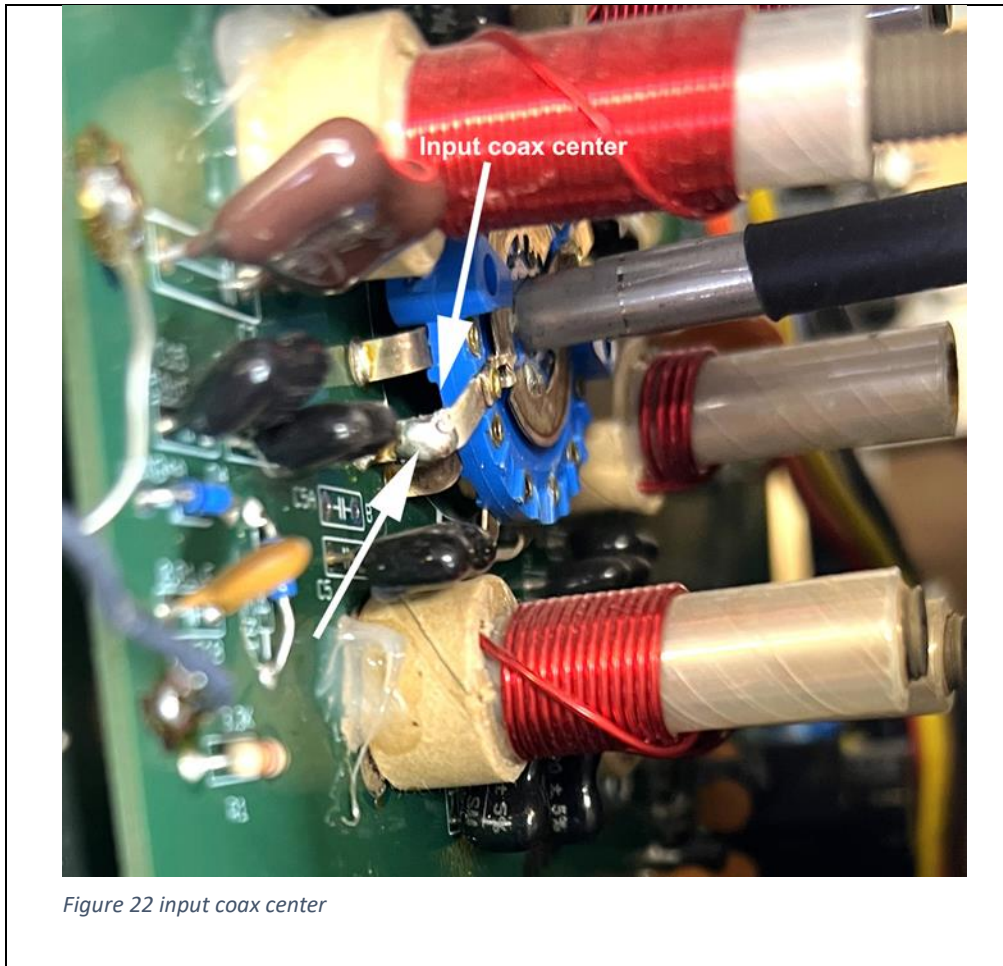


Figure 20 Attach lower wires



26.) Solder the center conductor to the input switch common connection. Do this by first tinning a good dot of solder on the switch common bar and a fresh dot on the coax center. Hold those fresh dots together steadily as you fuse them and let them cool. Do not let them wiggle while cooling



27.) The input coax shield goes to any close ground on the input board. The ALC pot ground or any component you are sure of will be okay. Feel free to shorten ground wires if they are loopy

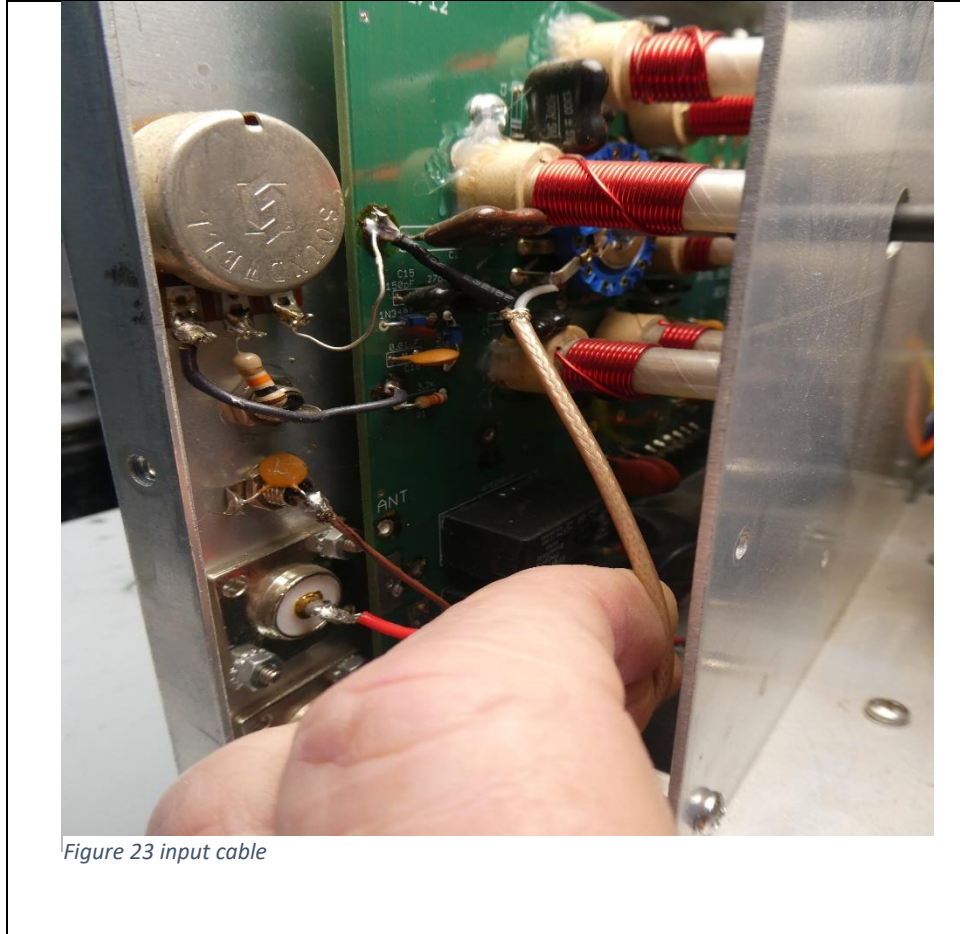


Figure 23 input cable

This should complete your installation.

## Preoperation Testing

The best “pretest” is a careful double-check of wiring. Inspect your work, then follow these ohmmeter tests on a low ohm scale.

- 1.) With amplifier off, there should be close to zero ohms from coax connector center-pin to center-pin. There should be infinite resistance center pin to chassis.
- 2.) Apply 12Vdc positive low current to any yellow meter lamp power, 12V fan kit power wire, or standby switch wire. Chassis is negative ground. The 12Vdc systems will run. This will allow you to key and test most relay functions with a “cold” amplifier.
- 3.) With the standby switch on standby, RELAY jack voltage should be zero.
- 4.) With the standby switch on operate, RELAY jack voltage should be 12Vdc. This is the relay jack voltage your radio will see.

- 5.) With the standby switch on operate, RELAY jack center pin current to chassis should be 80mA NOMINALLY. This is the relay system keying current the radio will see. The relays should make a faint click when current is drawn.
- 6.) With the relay jack center pin grounded and the standby switch on operate, the output connector center pin should be 30-80 ohms to chassis. This is the resistance of the reddish colored safety choke near the LOAD capacitor. This test confirms the RF tank is connected to the antenna on transmit.
- 7.) With the relay jack center pin grounded and the standby switch on operate, the input connector center pin should be infinite ohms to chassis. This test confirms the input circuit is isolated from the tank and other unwanted connections
- 8.) With the relay jack center pin grounded and the standby switch on operate, the input connector center pin should be nearly zero ohms to the input switch common. This test confirms the RF INPUT is connected to the input band switch on transmit
- 9.) When the RELAY jack is grounded and on operate, the XMT LED should illuminate. It should not illuminate on standby.

Do not operate the amplifier should any test fail.

Figure 1 basic board.....	1
Figure 2 relay timing worst case sample .....	2
Figure 3 UnRS811 board schematic.....	3
Figure 4 never ground shield to PC board!.....	4
Figure 5 unsolder and discard relay wires. This includes the brown/black, bare, or blue wire to the Relay jack.....	5
Figure 6 position relay .....	6
Figure 7 push harness in along back area.....	7
Figure 8 pull wire once through.....	7
Figure 9 route inside chassis lip to front.....	8
Figure 10 Bias wiring.....	8
Figure 11 early or no fan kit .....	9
Figure 12 PC board bias .....	9
Figure 13 Pre tin and route wires .....	10
Figure 14 RED harness to switch top lug .....	11
Figure 15 BROWN wire .....	12
Figure 16 BLUE wire .....	13
Figure 17 trial fit .....	14
Figure 18 board layout.....	15
Figure 19 Mount Board solder AMP out coax .....	16
Figure 20 Attach lower wires .....	17
Figure 21 Small Blue Keying wire.....	18
Figure 22 input coax center .....	19
Figure 23 input cable .....	20