

LDMOS ALS1300/1306 using CTR MRF300 Modules

Rev1 Apr2,2025

The MRF150 TMOS is a 1980s Motorola transistor. It was used in Ameritron amplifiers home station solid state amplifiers up until closing. TMOS is less forgiving for thermal runaway and junction failure than modern LDMOS. This modification uses four MRF300 LDMOS on each PA module for a total of eight MRF300 instead of the original eight MRF150.

This ALS1300/1306 LDMOS modification involves the following:

- 1.) PA modules are removed and a few holes are re-tapped. The heatsinks are refinished
- 2.) Two new MRF300AN and MRF300BN are installed and aligned on each remanufactured heatsink. This is a total of eight new transistors
- 3.) A new circuit board with all new parts is installed on the original remanufactured heatsinks and MRF300s
- 4.) The modules are pretested in a test fixture
- 5.) After testing, the modules are fitted back into the OEM amplifier
- 6.) The low pass filter board is inspected and tested for defects. Almost all filters have multiple problems
- 7.) The corrected filter board is reinstalled
- 8.) The 1300 control bias board has bias resistors changed. The LDMOS operates with less bias voltage, below 3 volts. The following CB1 (ALS1300) changes are made:
 - a. R54 and 55 are changed from 100 to 220 ohms to reduce bias voltage
 - b. A new 100 ohm shunts each set of pots to expand pot range
 - c. C20 and C21 are removed for fan speed control
 - d. R6 changes from 100K to 10K
 - e. R9 changes from 10K to 470 ohms
 - f. Fan speed resistors change. R38 and R39 become 1.5K ohms. R32 and R34 become 2.2K ohms.
- 9.) The 1306 control bias board has bias resistors changed. The LDMOS operates with less bias voltage, below 3 volts. The following CB1 (ALS1300) changes are made:
 - a. R147 and 152 are changed from 100 to 220 ohms to reduce bias voltage
 - b. A new 100 ohm shunts each set of pots to expand pot range
 - c. C68 and C69 are removed for fan speed control
 - d. R50 changes from 10K to 1K for PA balance
 - e. Fan speed resistors change. R135 and R139 2.2K. R136 and R138 change to 1.5K

COLD Bias is set at 250-300mA per transistor, the optimum value nulls harmonics. Without harmonic tests 300mA is used.

Operation

Use the old original manual for operation. This amplifier operates as before; it just has more headroom on transistors. I suggest staying at 1500W PEP on SSB and low duty cycle modes or below 20A per channel continuous PA current. The primary limit on high duty cycle is the power supply average current. 1500W CW is okay for normal CW contacts. For long transmission digital, FM, or RTTY modes 500-600 watts would be advisable, although 1500W is okay ICAS of less than 30 seconds transmission and 90 second cooling.

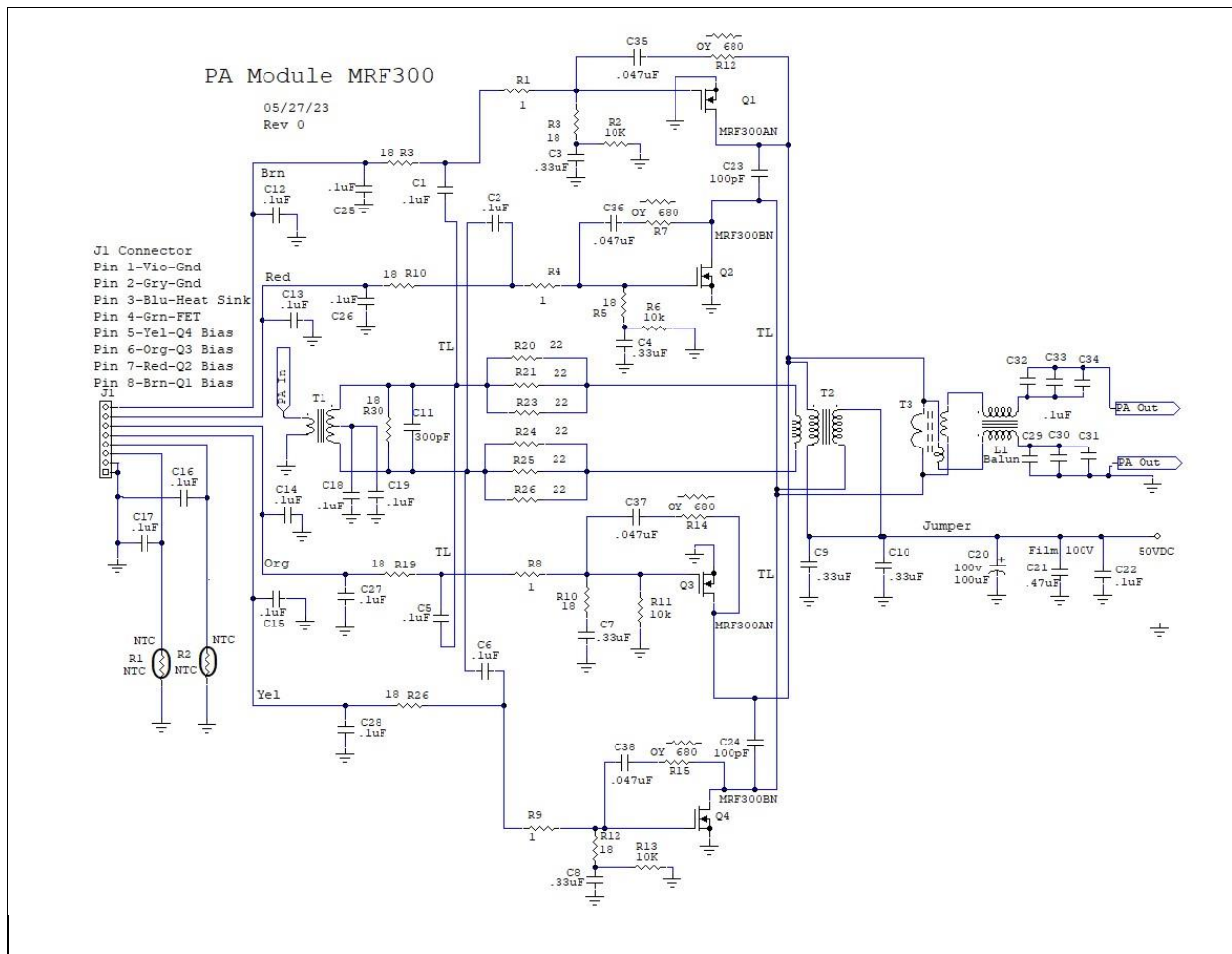

Gain vs. Drive LDMOS CTR 1306 20M

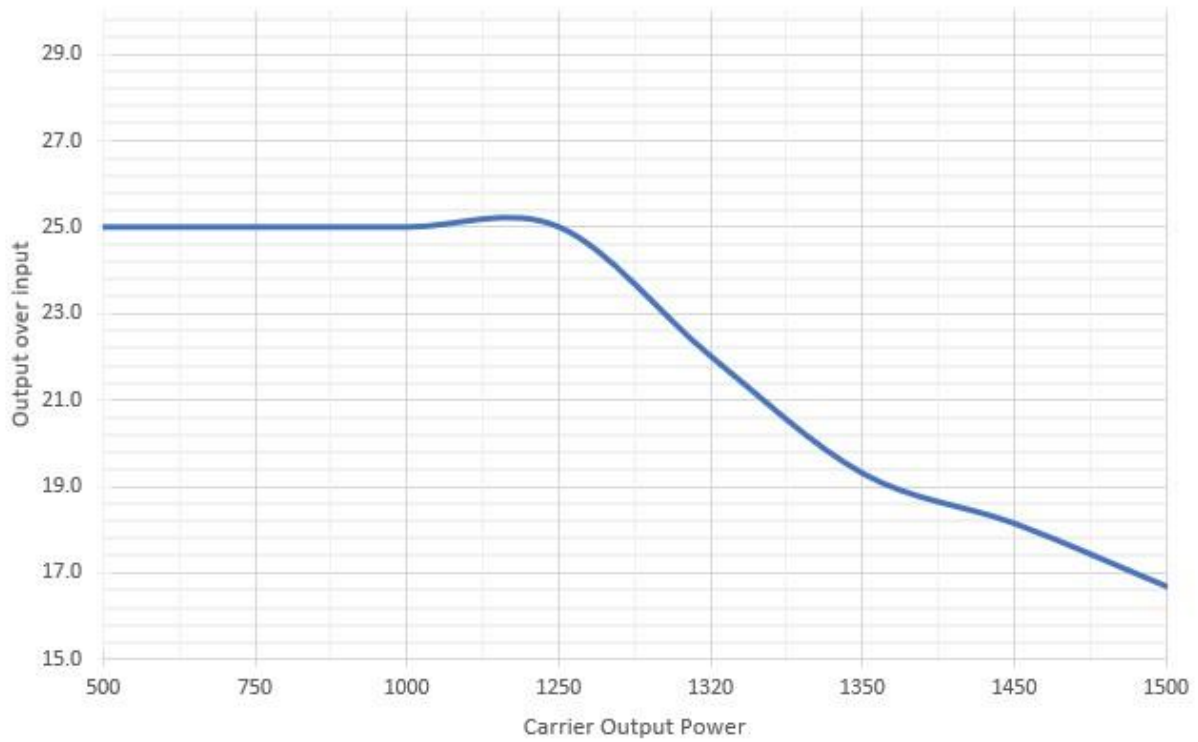

Because of gradual rounded transfer slope, 1500W will not cause excessive IMD.